



the complete range of
warmflow sanitary ware

Warmflow Sanitary

warmflow - the perfect choice

Warmflow has been established as a privately owned company since 1970. During this time we have developed into one of the UK and Ireland's leading manufacturers of heating appliances gaining a reputation for high quality, value for money products.

In addition to the production of heating appliances, Warmflow operates a fabrication workshop, manufacturing sheet metal components. We have developed a successful range of stainless steel sanitary ware, maintaining Warmflow's reputation for both quality and value for money

At the core of our success has been our commitment to quality:

'Quality manufacturing, sales support and back-up service.'

Our sanitary range of products are manufactured at a high standard to ensure reliability and quality.

In addition, to ensure that we maintain our own in house quality standards, we have in place a BSI approved monitoring system, certified to BS EN ISO 9001:2000

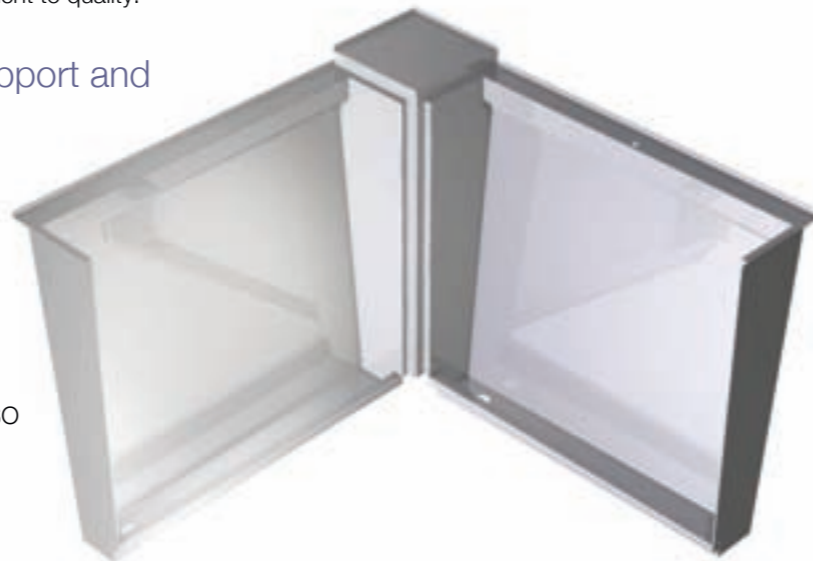

CERT No. FM29884

product index

standard range	
4-5	Standard Trough Urinal
premium range	
6	Premium Urinal Range
7	Premium Trough Urinal
8	Premium Slab Urinal
9	Premium Fresh Floor Urinal
complete solutions	
10	Urinal Assembly Configurations
10	Additional Sanitary Ware
installation and maintenance	
11	Installation
11	Maintenance



standard trough urinal

the “standard range” is competitively priced, easy to install and is available in a range of five standard lengths.

Warmflow’s ‘Standard range’ urinals are manufactured from grade 304 stainless steel. Standard trough urinals are wall hung and can easily be installed at either adult or junior heights.

This urinal has a vandal resistant concealed sparge which provides an even and effective non splash flush. Standard urinals are supplied with ends which are suitable for both free standing and built in applications. These competitively priced units have centrally positioned sparge connections and waste outlets. Each urinal is supplied with a 2” BSP domed grated waste fitting, cistern and 22mm flush downpipe.

Configurations

Ends suitable for free standing & built in

Sparge connection and waste outlet positioned centrally

Concealed sparge

Complete with flush downpipe and cistern

2” BSP domed grated waste

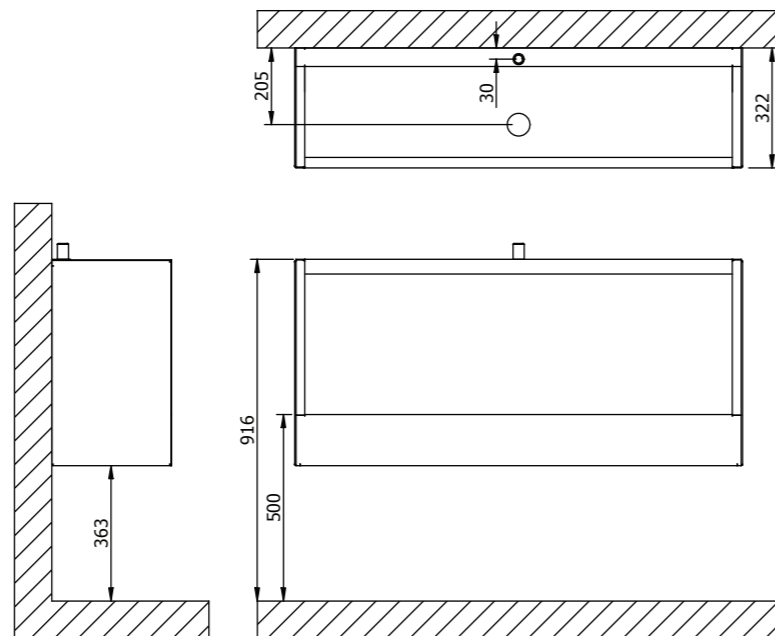

installation

The Standard urinal is easy to install in all free standing or built in applications. The urinal comes complete with wall mounting brackets.

The urinal is hung on the wall brackets ensuring a level horizontal top surface is attained.

Securing holes are also present underneath the trough located on the end’s return fold.

urinal sizes & cistern capacity

The standard urinal comes in five different lengths; 1200, 1500, 1800, 2100 & 2400mm.

The urinal is supplied with a plastic or optional stainless steel automatic flushing cistern.

The recommended mounting height is between 1800 - 2000mm from finished floor level to the underside of the cistern.

The urinal also comes with a 22mm stainless steel downpipe with corresponding fittings and fixings.

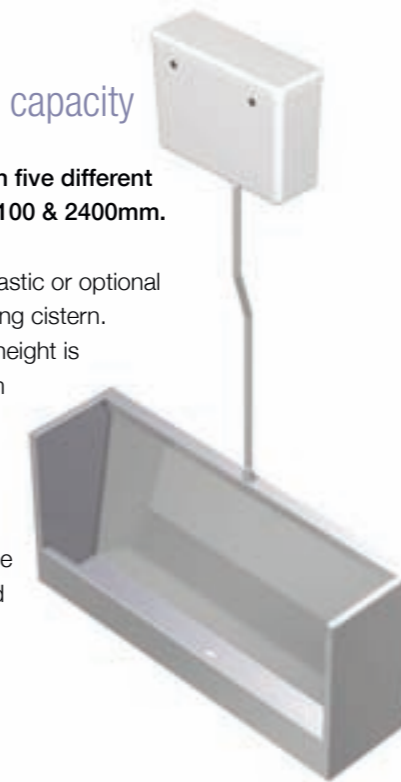

Urinal Code	UTS12	UTS15	UTS18	UTS21	UTS24
Urinal Length	1200mm	1500mm	1800mm	2100mm	2400mm
Cistern Capacity	9 litres	13.5 litres	13.5 litres	13.5 litres	13.5 litres



Benefits

Quality product at a competitive price

Ease of installation

Robust and Vandal resistant

Hygienic design and easy to maintain

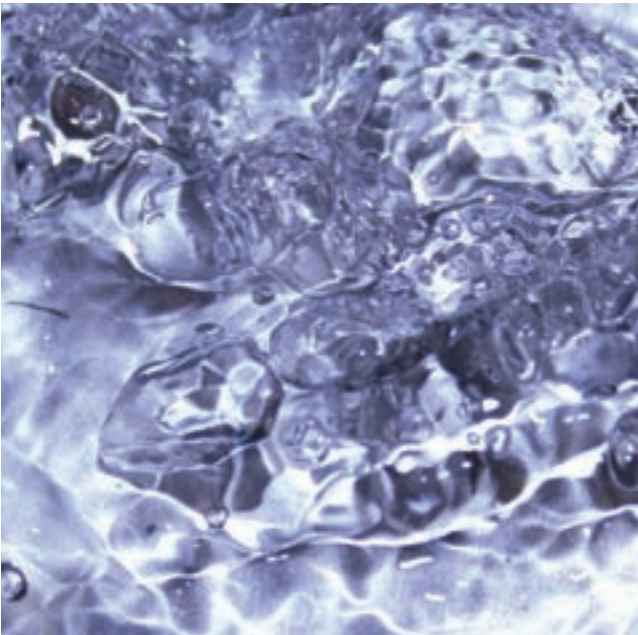

premium urinal range

warmflow's premium urinal range provides a complete bespoke urinal solution.

The premium urinal range is manufactured using 304 grade satin finish stainless steel.

The premium range urinals are manufactured with vandal resistant concealed sparge pipes as standard giving a non splash flush.

The sparge inlet can be positioned to the customer's specification along the length of the urinal exiting on the top, back or one of the urinal ends.

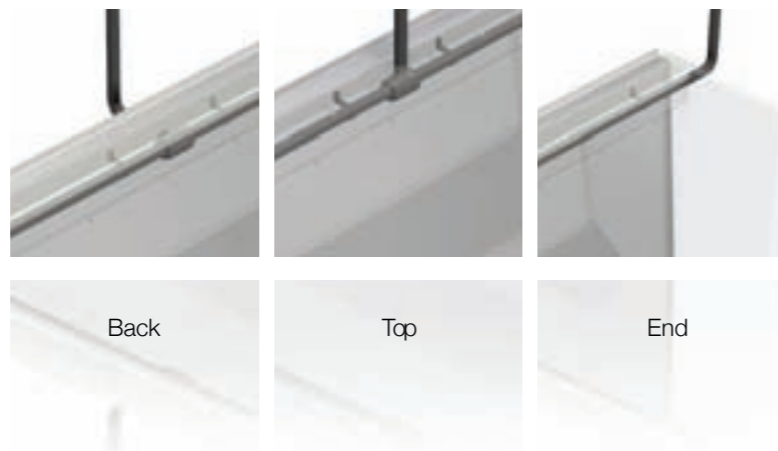

Urinals are supplied with built in ends as standard but are also available with free standing ends or a combination of both. Free standing ends are an optional extra at a minimal cost. One piece urinals can be supplied up to a maximum length of 3m; joined urinals available for lengths over 3m.

We also manufacture corner or filler ends for all varieties of urinals. Urinals are supplied with a 2" BSP chrome domed grate waste fitting, positioned at either end of the urinal depending on customer requirements.

premium trough urinal

trough urinals are wall hung and can easily be installed at either adult or junior heights.

Trough to floor closure panels are available on request at extra cost. These panels are manufactured with a maintenance access hole positioned adjacent to the waste outlet.

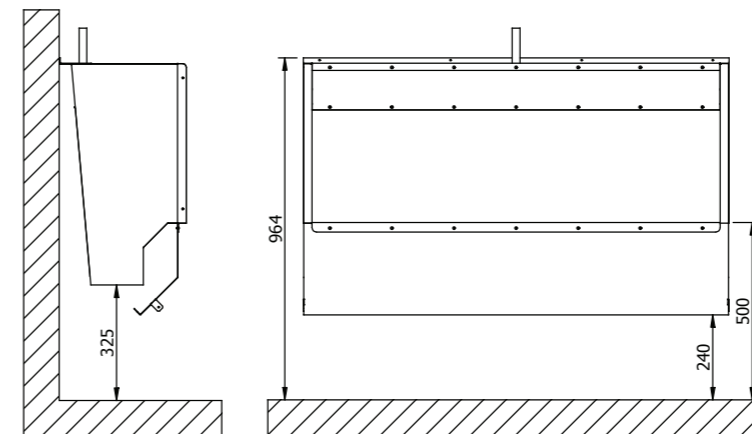
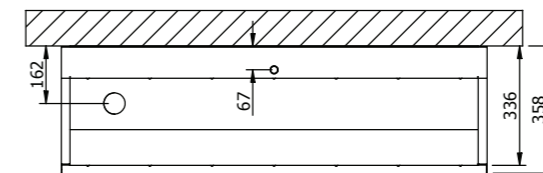

Configurations

Ends available as free standing or built in

Sparge outlet positions: top, back & end

Sparge position customisable

Optional Closure Panel

Waste outlet position: left, right

premium slab urinal

slab urinals are installed either below floor level or built into a raised platform.

They come with built in ends as standard but free standing ends are available at an additional cost.

premium fresh floor

the optimum hygienic solution where cleanliness is critical.

The fresh floor urinal is manufactured with a second sparge outlet positioned under the grid platform. This second sparge allows for a flow of water to clean the surface of the urinal.

The grid platform can be installed at either floor level or raised to allow the urinal to be built into an elevated step.



Configurations

Ends available as free standing or built in

Sparge outlet positions: top, back & end

Sparge position customisable

Waste outlet position: left, right

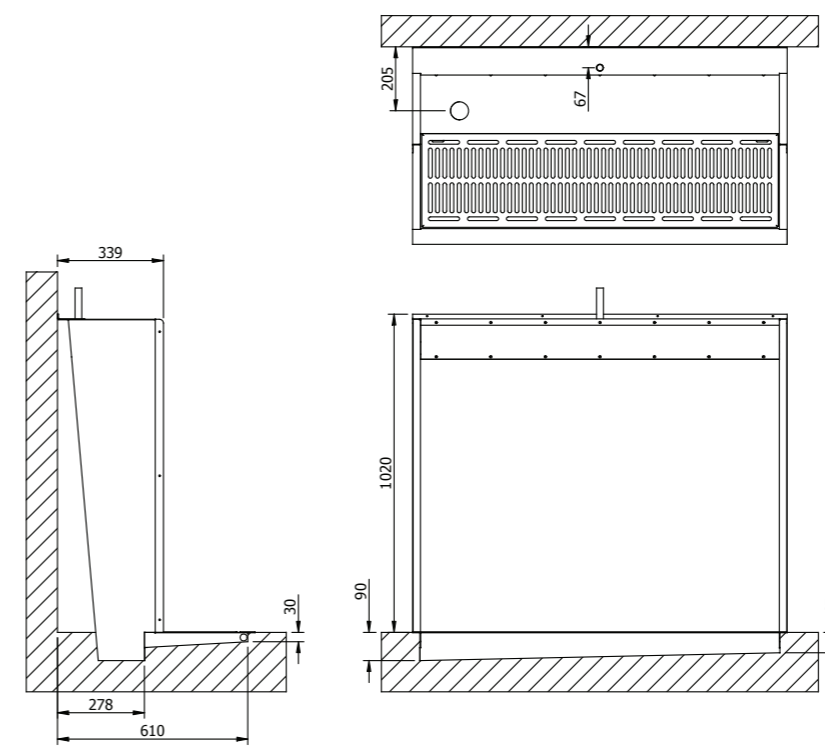
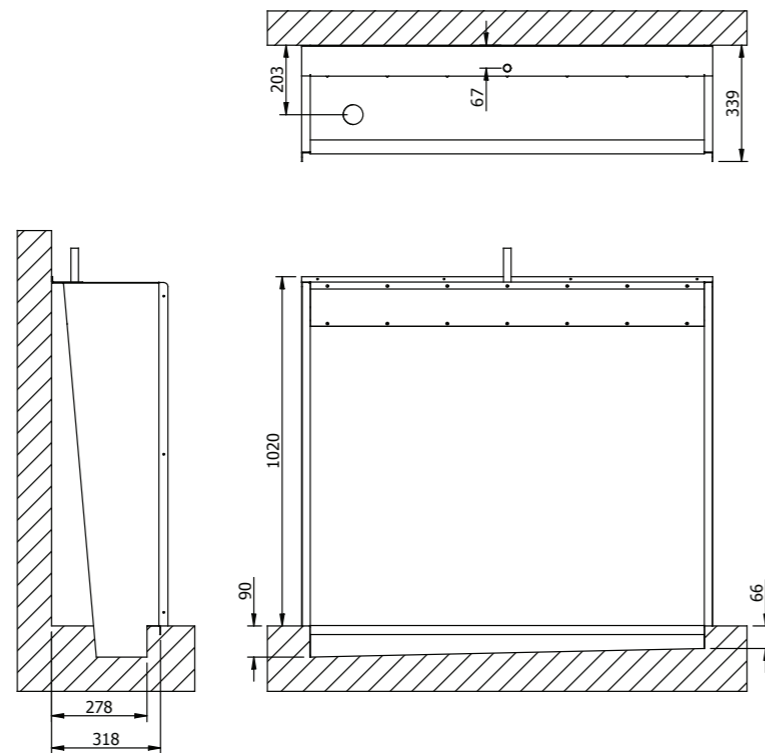

Configurations

Ends available as free standing or built in

Sparge outlet positions: top, back & end

Sparge position customisable

Waste outlet position: left, right



urinal assembly configurations

Premium urinals can also be manufactured in sections to accommodate restricted access. The urinals can be manufactured in straight, corner or u-shaped configurations.

Manageable individual sections along with their corresponding joining strips or corner plinths are supplied with appropriate fixings for assembly on site.



additional sanitary ware

stainless steel hand wash troughs.

In addition to stainless steel urinals Warmflow manufacture a wide range of sanitary ware products suitable for many applications such as hand troughs, toilet cubicles, shower trays, etc.

Please contact us for more information.



installation

Urinals must be installed ensuring that the top edge is horizontal and the urinal ends are vertical. Warmflow urinals come with pre-drilled fixing holes for ease of installation. Warmflow Premium Urinals are supplied with a 2" BSP chrome dome grated waste and the sparge flushing system is supplied with a standard 22mm stainless steel pipe allowing for quick and effortless installation.

In order to conserve water supplies, one of the following three methods must be employed to prevent the flow of water to urinal cisterns during periods when the building is unoccupied:

1. A time operated switch controlling a solenoid valve which cuts off the water supply to the urinal flushing cistern(s).
2. An 'impulse' initiated automatic system which only permits water to pass to a urinal cistern when other appliances are used (i.e. when tap is switched on).
3. A proximity or sensor control device is installed.

Manually operated flushing systems must only be used to supply single user urinals. Urinals must have a flushing system that is capable of delivering 1.5 litres per user position every time the flushing device is operated.

For more information please consult Local Water Supply Regulations.

maintenance & cleaning

In order to preserve the life of the stainless steel and maximise the resistance to corrosion the surface must be cleaned thoroughly on a regular basis. Particular attention must be made to non-flush surfaces of the urinal.

Warmflow recommends that urinals are cleaned along the grain of the stainless steel surface using warm water and a mild detergent with a sponge or soft cloth and must be thoroughly rinsed after washing.

Note:

Chlorine based cleaning agents and abrasive materials must not be used.

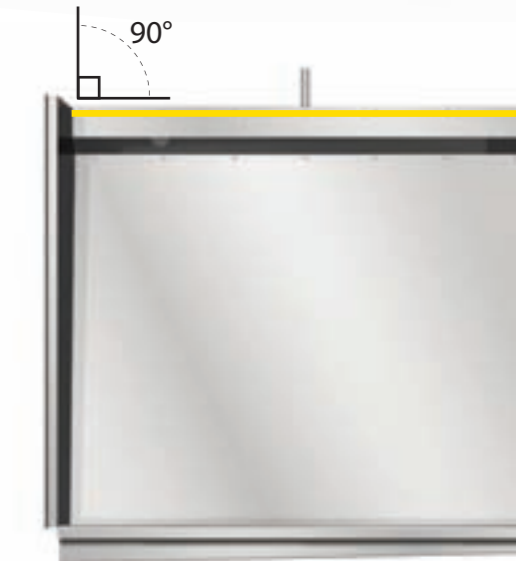
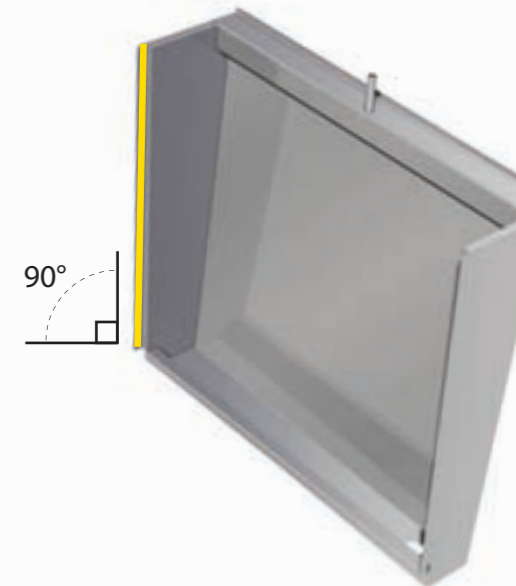

All of our items are manufactured to a high standard and come with a 1 year warranty.

If you would like more information on any items from our sanitary range please get in touch and a member of our sales team will be delighted to help.



quality design with built-in reliability

Warmflow Engineering Co Ltd manufactures a range of products including heating and ventilation, renewable energy, washroom products and gun cabinets, as well as precision sheet metalwork and bespoke fabrication in a variety of materials. All of our product brochures can be viewed or downloaded at warmflow.co.uk and are also available in hardcopy upon request.



Warmflow Boilers (brochure 3509)

- Oil-fired boilers
- Gas - fired boilers
- Flue systems



Warmflow Solar (brochure 3549)

- Vacuum tube collectors
- Flat panel collectors
- Twin coil unvented cylinders



Warmflow Sanitary (brochure 3511)

- Standard urinals
- Premium urinals
- Sanitary ware solutions



Warmflow Fabrication (brochure 3576)

- General fabrication
- Subcontract manufacture
- Warm air heaters and ducting
- Gun cabinets

Head Office (NI)

Warmflow
Lissue Industrial Estate
Moirra Road
Lisburn
BT28 2RF

Tel: 028 9262 1515
Fax: 028 9262 0869
Email: sales@warmflow.co.uk

ROI

Tel: 048 9262 1515
Fax: 048 9262 0869
Email: sales@warmflow.co.uk

GB

Tel: 01952 607750
Fax: 01952 603983
Email: salesgb@warmflow.co.uk



CERT No. FM29884

Warmflow Engineering Company Limited maintains a policy of continuous product improvement and reserves the right to change specification without notice. The statutory rights of the customer are not affected. This brochure should only be used for sales purposes. Please consult the installation instructions before installing or specifying a Warmflow product which are available on request.